



Magdalena, Cutting edge *Beauty.*

design Bruno Rainaldi
terzani.com



Type		Suspension
Materials		Metal
Finishes		Code
White		0M61S E8 C8
Nickel		0M61S G8 C8
Gold		0M61S H5 C8

Light Source |



Reaching inside traditional forms, Magdalena's laser-cut, horizontal openings allow for its light to expand its range to the entire room. Creating an alluring pattern of light and shadow, Magdalena highlights the shape of the room itself. This unique exchange creates a pendant that impacts every space, regardless of size. Design Bruno Rainaldi.



Body |

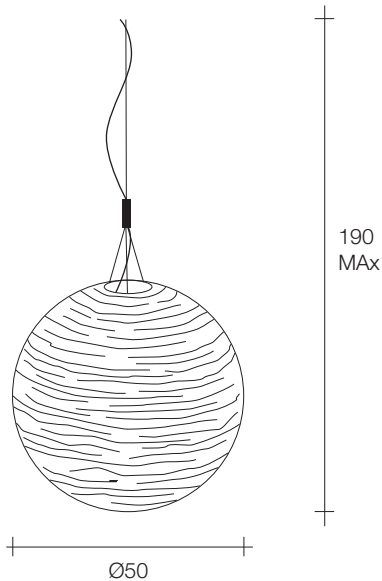

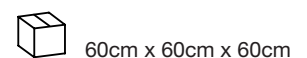

Canopy |



Magdalena, Cutting edge *Beauty.*

design Bruno Rainaldi
terzani.com



Type		Suspension
Materials		Metal
Finishes		Code
White		0M62S E8 C8
Nickel		0M62S G8 C8
Gold		0M62S H5 C8

Light Source |



Reaching inside traditional forms, Magdalena's laser-cut, horizontal openings allow for its light to expand its range to the entire room. Creating an alluring pattern of light and shadow, Magdalena highlights the shape of the room itself. This unique exchange creates a pendant that impacts every space, regardless of size. Design Bruno Rainaldi.



Body |

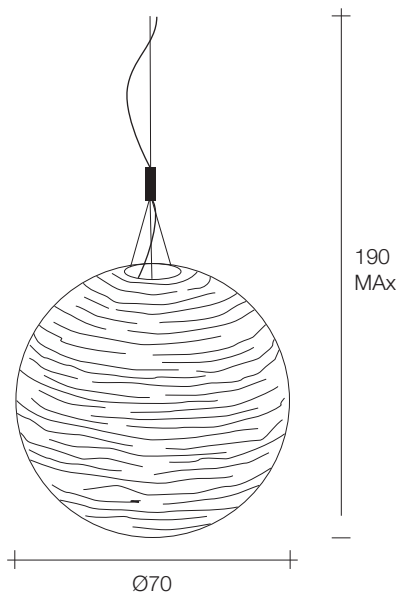

Canopy |

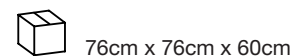

Magdalena, Cutting edge *Beauty.*

design Bruno Rainaldi
terzani.com

TERZANI
LA LUCE PENSATA



Type | Suspension

Materials | Metal

Finishes | **Code**

White  0M65S E8 C8

Nickel  0M65S G8 C8

Gold  0M65S H5 C8

Light Source |



Reaching inside traditional forms, Magdalena's laser-cut, horizontal openings allow for its light to expand its range to the entire room. Creating an alluring pattern of light and shadow, Magdalena highlights the shape of the room itself. This unique exchange creates a pendant that impacts every space, regardless of size. Design Bruno Rainaldi.



Body |

Canopy |

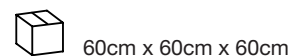
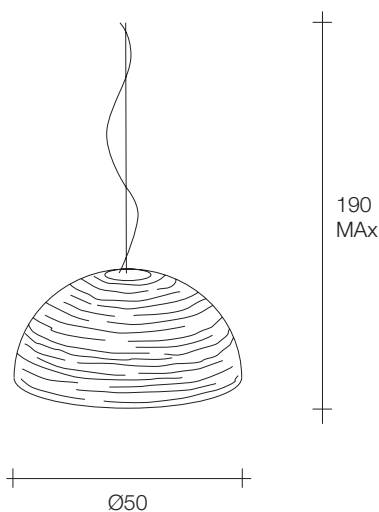

Magdalena, Cutting edge *Beauty.*

design Bruno Rainaldi
terzani.com

TERZANI
LA LUCE PENSATA



Type | Suspension

Materials | Metal

Finishes | **Code**

White  0M66S E8 C8

Nickel  0M66S G8 C8

Gold  0M66S H5 C8

Light Source |



Reaching inside traditional forms, Magdalena's laser-cut, horizontal openings allow for its light to expand its range to the entire room. Creating an alluring pattern of light and shadow, Magdalena highlights the shape of the room itself. This unique exchange creates a pendant that impacts every space, regardless of size. Design Bruno Rainaldi.



Body |

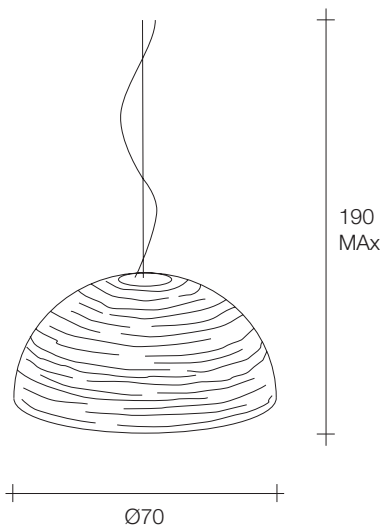

Canopy |

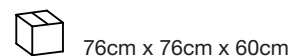

Magdalena, Cutting edge *Beauty.*

design Bruno Rainaldi
terzani.com

TERZANI
LA LUCE PENSATA



Type | Floor lamp

Materials | Metal

Finishes | **Code**

White  0M63P E8 C8

Nickel  0M63P G8 C8

Gold  0M63P H5 C8

Light Source |



HALOGEN
ES
105W E27
(=150W)

Reaching inside traditional forms, Magdalena's laser-cut, horizontal openings allow for its light to expand its range to the entire room. Creating an alluring pattern of light and shadow, Magdalena highlights the shape of the room itself. This unique exchange creates a pendant that impacts every space, regardless of size. Design Bruno Rainaldi.



Body |

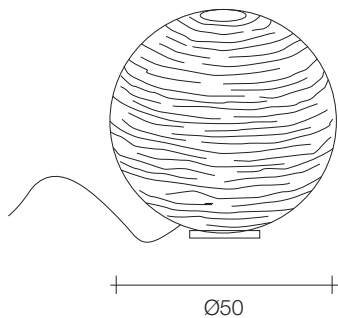

Canopy |



12,5



6



60cm x 60cm x 60cm

Magdalena, Cutting edge *Beauty.*

design Bruno Rainaldi
terzani.com



Type | Floor lamp

Materials | Metal

Finishes | **Code**

White  0M64P E8 C8

Nickel  0M64P G8 C8

Gold  0M64P H5 C8

Light Source |



HALOGEN
ES
140W E27
(=200W)

Reaching inside traditional forms, Magdalena's laser-cut, horizontal openings allow for its light to expand its range to the entire room. Creating an alluring pattern of light and shadow, Magdalena highlights the shape of the room itself. This unique exchange creates a pendant that impacts every space, regardless of size. Design Bruno Rainaldi.



Body |

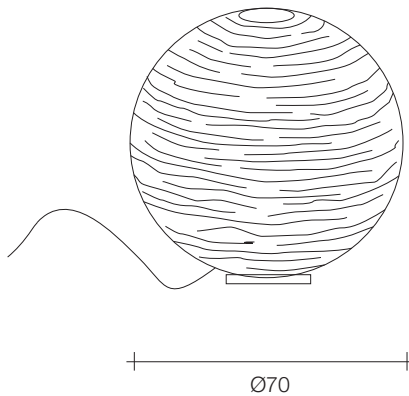

Canopy |



17



13



76cm x 76cm x 60cm